



# The Consumer Electronics Industry

Industry  
Guidelines for the  
Numbering and  
Bar Coding of  
Trade Items

Version 2.2



# Document Change Control

Document Version Number	Date of Change
Version 2.1	December 2006
Version 2.2	April 2010

## Document History/Summary of Changes

Version	Date	Revision Comments
Final Version	August 2002	
Version 2.0	August 2004	Addition of requirements for numbering and bar coding T2 type products.
Version 2.2	April 2010	Re-structured to new template.

## Contacts

The principle contacts with regard to the contents of this document are:

GS1 Australia Ltd  
Axxess Corporate park  
Unit 100/45 Gilby Road  
Mt Waverley VIC 3149  
Australia

Telephone: 1300 366 033  
Facsimile: (03) 9558 9559  
Internet Web Site: [www.gs1au.org](http://www.gs1au.org)  
E-mail address: [gs1aust@gs1au.org](mailto:gs1aust@gs1au.org)

These guidelines should be read in conjunction with the **GS1 Australia User Manual - Numbering and Bar Coding**.

## Disclaimer

Every possible effort has been made to ensure that the information and specifications in this manual are correct, however GS1 Australia Consumer Electronics Industry expressly disclaim liability for any errors. In addition, no warranty or representation is made that this manual will not require modification due to developments in technology or changes or additions to the GS1 System.



# Acknowledgements

This Numbering and Bar Coding Guideline for the Australian Consumer Electronics Industry was developed by GS1 Australia in conjunction with Applie-com.

Applie-com members include the following organisations:

• Breville	• Electrolux
• Fisher & Paykel	• Harvey Norman
• The Good Guys	• Panasonic
• Phillips	• Samsung
• Sony	• Sunbeam
• NARTA	

# Contents

<b>1</b>	<b>Executive Summary</b>	<b>3</b>
<b>2</b>	<b>Introduction and Overview</b>	<b>4</b>
2.1	Who is GS1 Australia	4
2.2	The GS1 System	4
<b>3</b>	<b>Benefits of Implementation</b>	<b>6</b>
<b>4</b>	<b>How to Number and Bar Code Trade Items</b>	<b>7</b>
4.1	Definition of Trade Item	7
4.2	Attributes of Trade Items	8
4.3	Difference between Numbering and Bar Coding	11
4.3.1	Numbering	11
4.3.2	Bar Coding	11
4.4	Numbering, Bar Coding and packaging levels	12
4.5	Fixed Measure Trade Items Sold at Retail Point-of-Sale (POS)	14
4.5.1	GTIN-13	14
4.5.2	GTIN-8	15
4.5.3	GTIN-12	15
4.6	Variable Measure Trade Items Sold at Retail Point-of-Sale (POS)	15
4.7	Fixed Measure Trade Items Non-Retail (General Distribution)	16
4.7.1	Definition	16
4.7.2	Options for Trade Items NOT sold at Retail Point-of-Sale (POS)	16
4.8	Variable Measure Trade Items NOT Sold at Retail Point-of-Sale (POS)	19
4.9	Location of the Bar Code on Trade Items	20
4.9.1	Trade Items Sold at Retail Point-of-Sale (POS)	20
4.9.2	Trade Items NOT Sold at Retail Point-of-Sale (POS)	21
<b>5</b>	<b>How to Number and Bar Code Logistic Units</b>	<b>22</b>
5.1	Serial Shipping Container Code (SSCC)	22
5.2	How to Allocate the Serial Shipping Container Code (SSCC)	23
5.3	The Logistics Label	24
5.3.1	Components of the GS1 Logistics Label	24
5.3.2	Label Design	25
5.3.3	Label Dimensions	26
5.3.4	Technical Specifications	26
5.4	GS1 Logistics Label Formats for the Australian Consumer Electronics Industry	27
5.5	Location of Logistic Unit Label	32
5.5.1	Cartons and Outer Cases	32
5.5.2	Pallets	33
<b>6</b>	<b>Global Location Numbers</b>	<b>34</b>
6.1	Introduction	34
6.2	Definition of the Global Location Number (GLN)	34
6.3	Implementation Timing	35
<b>7</b>	<b>Asset Numbering</b>	<b>36</b>
<b>8</b>	<b>Appendix</b>	<b>37</b>



<b>8.1</b>	<b>Bar Code Quality Check List.....</b>	<b>37</b>
<b>8.2</b>	<b>Emerging Technologies .....</b>	<b>38</b>
8.2.1	EPC Network & Radio Frequency Identification (RFID) .....	38
8.2.2	GS1 DataMatrix .....	38
<b>8.3</b>	<b>Services Offered by GS1 Australia.....</b>	<b>39</b>
8.3.1	Introduction .....	39
8.3.2	The Services .....	39



# 1 Executive Summary

As the Consumer Electronics Industry in Australia seeks to adopt the key principles of ECR there is increased demand for improved data capture at all points of the supply chain. This should be a key objective for all trading partners if they are to effectively meet their company's needs and exceed customers' expectations.

The efficient servicing of customers is the process of supplying the right products, right quantity, right price and right quality at the right time and place with a minimum of effort. The benefits are the avoidance of wasted effort, measured in terms of low cost and high levels of customer service.

Achieving efficiency in the management of the supply chain relies on having fast, accurate and timely information about production, distribution and consumption. The need for a highly responsive supply chain is driving forward the development of communication techniques. Technologies such as automatic data capture (through the use of bar coding or RFID), electronic messaging, and data synchronisation are essential for this communication. Any company serious about exploiting the concepts and practices of supply chain management must be competent in the use of these technologies. Nothing is more central to the effectiveness of a supply chain than the ability to transmit accurate, relevant, understandable and timely information among its participants.

These recommendations for best practice encompass the main requirements of the Australian Consumer Electronics Industry. Adoption of these recommendations should bring improved business efficiency and effectiveness for all companies within the supply chain.

These guidelines are a recommendation only. Before implementation please consult your trading partners for specific requirements above and beyond this document.



## 2 Introduction and Overview

The GS1 System originated in the United States and was established in 1973 by the Uniform Code Council (UCC), now known as GS1 US. The UCC adopted a 12-digit identification number, and the first identification numbers and bar codes in open trade were being scanned in 1974.

Following the success of the UCC System, the European Article Numbering Association (now known as GS1), was established in 1977 to develop a compatible system for use outside North America.

Today, full global compatibility is achieved through the use of the Global Trade Item Number (GTIN), an 8, 12, 13, or 14-digit number that is unique worldwide. The GS1 System is designed for use in any industry or trade sector, at all levels of manufacturing and distribution. In Australia, major system adopters include the grocery, health, steel, hardware, consumer electronics, furniture, meat and telecommunications industries. The GS1 System is even used for fire brigades and electricity generators.

The following information contains guidelines on how to number and bar code trade items using the GS1 standards for the Australian Consumer Electronics Industry.

The versatility of the GS1 System provides users with various numbering and bar coding options. It is left to the discretion of manufacturers and suppliers to decide which option is suitable to their business needs and those of their trading partners.

### 2.1 Who is GS1 Australia

GS1 Australia is part of the not-for-profit GS1 global organisation and locally administers the GS1 System in Australia.

Created to help Australian business enterprises to become more efficient, GS1 Australia's fundamental role is to allocate GS1 Identification Numbers, maintaining internationally accepted trading standards. This in turn allows Australian organisations to adopt world's best practice supply chain management techniques.

Today, over 1 million member companies, serviced by offices in 108 countries, use the GS1 standards as part of their daily business communications, representing over five billion scanning transactions a day.

The today's GS1 Australia organisation was formed in 1978 as *the Australian Product Numbering Association (APNA)*, which was named *EAN Australia* from 1993 to 2005.

### 2.2 The GS1 System

The GS1 System permits organisations of any size to order, track, trace, deliver and pay for goods across the supply chain, anywhere in the world.

As illustrated in the Figure 1 on page 5, GS1 Solutions and Services using the GS1 System include:

GS1 Identification Keys: GS1 Identification Keys are the keys to accessing information about a product (or any physical or non physical item) on a computer file. The numbers are unique, non significant and global. They can be allocated to trade items, logistic units, locations, assets, shipments, consignments, documents and service relationships. The main elements of the numbering system are GTIN, SSCC, GLN and the Attribute Data. Please contact GS1 Australia for a full list of a GS1 Identification Keys.



**Bar Codes:** Within the GS1 System, data carriers (most commonly bar codes) are used to encode the GS1 Identification Keys to facilitate communication, data collection and exchange of information and smooth the flow of information between trading partners.

**eMessaging:** GS1 EANCOM and Business Messaging Standards for eMessaging (based on XML) are based on the principle of the transfer of structured data, using agreed messaging standards from one computer application to another by electronic means and with a minimum of human intervention. The structure and data content are exchanged by agreed means by trading partners. The electronic exchange of data or eMessaging provides trading partners with an efficient trading tool for the transmission of data.

**Figure 1: the GS1 System**

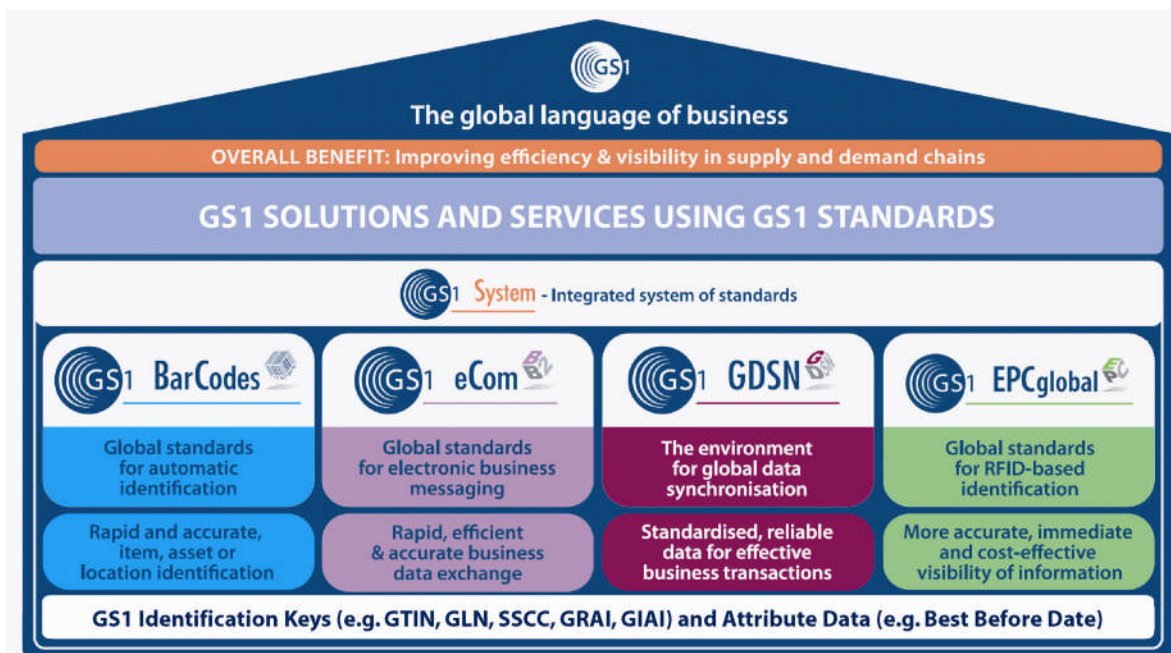

**GS1 GDSN:** The GS1 Global Data Synchronisation Network (GDSN) is a concept developed by various industry groups, including Global Commerce Initiative (GCI) and GS1 to assist industries streamline their supply chain transactions with the aim of reducing supply chain costs. The GS1 GDSN is an internet based interconnected network of interoperable data posted to a global registry that enables companies around the globe to exchange and synchronise supply chain master data with their trading partners. GS1net is the GDSN Data Pool run by GS1 Australia.

**EPCglobal:** The EPC (Electronic Product Code) Network is an open standards-based system that will make organisations more effective through real and timely visibility of information about items in the supply chain. This new, open global standard combines Radio Frequency Identification technology (RFID), existing communications network infrastructure and the EPC (a number for uniquely identifying an item) to create cost-efficient, real-time, accurate information about the location of items, the history of items, and the number of items in the supply chain. It is based on research conducted through the Auto-ID Centre with the support of more than 100 leading companies.

The EPC Network is comprised of five fundamental elements:

- Electronic Product Code (EPC)
- EPC Tags and Readers
- Object Name Service (ONS)
- Physical Markup Language (PML)
- Middleware (Application Level Event Software)



# 3 Benefits of Implementation

Using a standard common approach to the numbering and bar coding of trade items, logistic units, locations, assets, and documents, amongst others, will deliver the benefits of speed, accuracy and labour savings in the handling and distribution of goods throughout the entire supply chain. Companies should consider that the implementation of the GS1 standards is applicable not only to meet customer or trading partner demands but also to improve internal supply chain management. The benefits listed below are defined generically for users throughout the entire supply chain and not just the end user.

Some of the specific identified benefits are:

- More accurate information
- Real-time information
- Reduced manual entry
- Improved traceability (including for product recalls/withdrawals)
- Common identification across Industry
- Improved stock handling
- Improved stocktaking
- Reduced picking errors
- Reduce customer order errors

The numbering and bar coding of trade items supports the following supply chain functions:

**Figure 2: Numbering and Bar Coding Benefits along the Supply Chain**

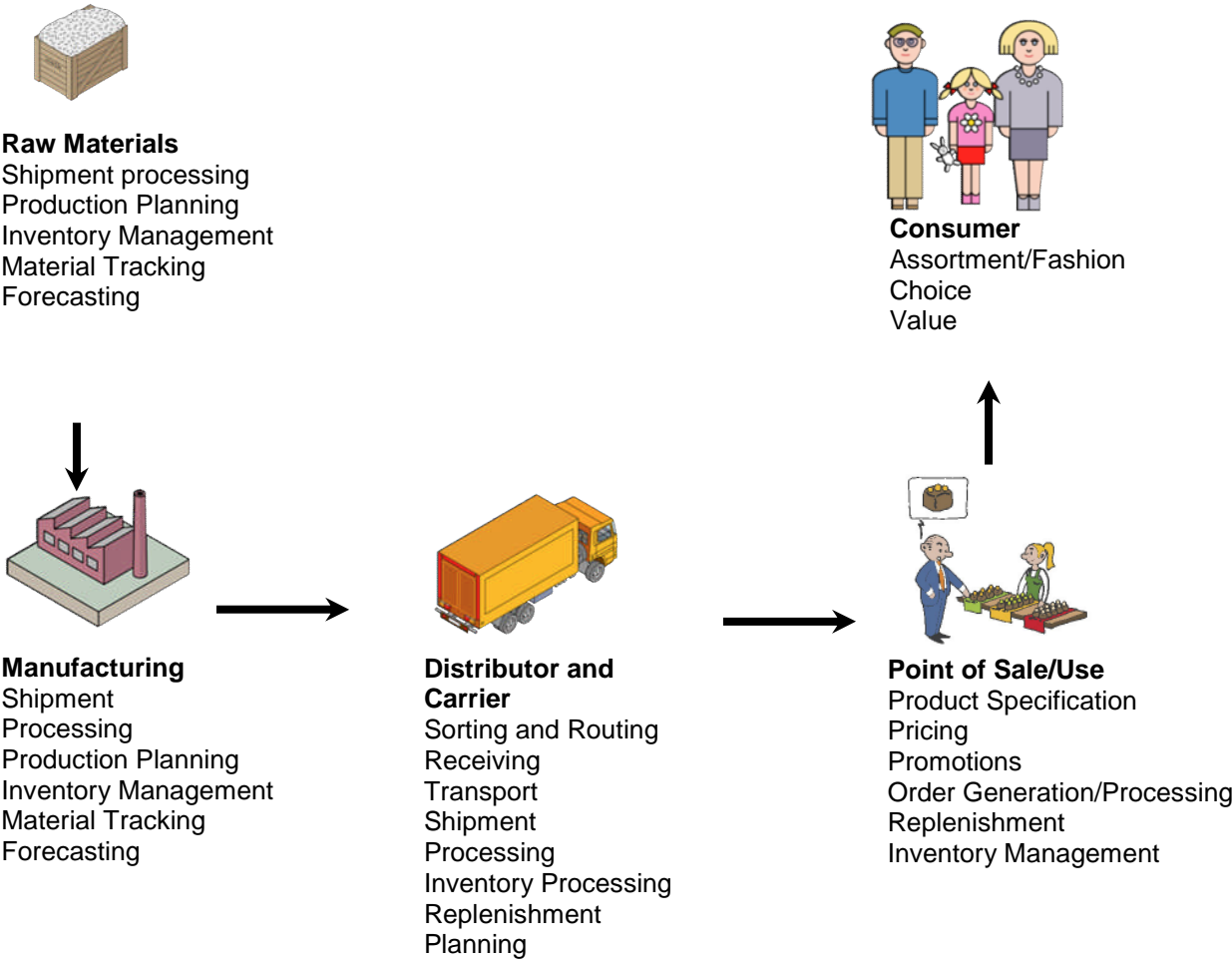

# 4 How to Number and Bar Code Trade Items

## 4.1 Definition of Trade Item

A trade item is any item (product or service) upon which there is a need to retrieve pre-defined information and that may be priced or ordered or invoiced at any point in any supply chain. This definition covers raw materials through to the end user products and also includes services, all of them having pre-defined characteristics.

A trade item may be a single, non-breakable unit; it may also be a standard and stable grouping of a series of single items. Such a unit may be presented in a wide variety of physical forms: a fibreboard carton, a covered or banded pallet, a film-wrapped tray, a crate with bottles, etc. Trade items consisting of single units are identified with a unique Global Trade Item Number (GTIN); standard groupings of identical or different units are identified with separate unique GTINs.

The GTIN can be represented in one of four ways:

- GTIN-8
- GTIN-12
- GTIN-13
- GTIN-14

A separate GTIN must be assigned to every different variation of a product. Size, style, grade, colour, etc are all considered separate variations and thus require separate GTINs.

Any change to trade items, such as weight, description, etc may require the allocation of another GTIN. In this event consult [www.gs1.org](http://www.gs1.org) and follow the links to “GTIN Allocation Rules” for guidance on when a change of GTIN is required, or contact GS1 Australia for further information.

When allocating GTINs in any of the formats described in the following sections, GS1 Australia recommends that no significance is created within the GTIN itself. Data is linked via a database to the GTIN, thus no level of understanding is required within the number itself.

**Note:** A GTIN allocated to a trade item that has become obsolete must not be re-used for another trade item until at least 48 months (4 years) has elapsed after:

- The expiration date of the last original trade items produced with that GTIN, or
- The last original trade items produced with that GTIN have been supplied to the customer

Companies may choose to extend the period of time before a GTIN is re-used beyond the minimum of four years; this is perfectly acceptable.

Consideration should be given to items which may exist in the marketplace for a longer period. For example, steel beams may be stored for many years before entering the supply chain, and processes should be put in place to ensure that the GTIN is not reallocated for a significant period of time.

In addition, when contemplating the re-use of a GTIN, consideration should be given to the use of data associated with the original GTIN by trading partners for statistical analysis or service records, which may continue long after the original trade item was last supplied.

Further consideration should be given to trade items in the healthcare sector, where it has been determined that GTINs will never be re-issued, for the purposes of patient safety.



## 4.2 Attributes of Trade Items

Attribute information of trade items is any data over and above the item identifier, ie. the GTIN. Examples of this type of information include batch numbers, serial numbers and variable measure information such as length, weight etc.

Attribute information is represented by GS1 Application Identifiers (AIs) and these ensure that the attribute information can be interpreted unambiguously by trading partners throughout the entire supply chain.

In “principle” the Australian Consumer Electronics Industry supports the use of variable data in the long term. Individual companies need to make their own assessment on the implementation and use of variable data in their business. Suppliers may wish to enhance the traceability of their own products by introducing additional information over and above the allocation of a GTIN to each trade item. For a complete list of AIs refer to the **GS1 Australia User Manual-Numbering and Bar Coding** which can be found at [www.gs1au.org](http://www.gs1au.org)

All attribute information must be represented in a GS1-128 Bar Code. When attribute information is applied to a trade item that is sold at POS it can be added along side the EAN-13 Bar Code, (see below). Where the trade item will not be sold at the retail POS attribute information can be concatenated (linked together) with the GTIN, in one single GS1-128 Bar Code as shown in insert cross reference to applicable section.

Example: **Figure 3: Attribute information used for traceability**



**Note:** Bar code size is not to scale. The GTIN-13 is encoded in an EAN-13 Bar Code, the attribute information, such as expiry date, batch/lot number or serial number are encoded in a GS1-128 Bar Code. Only the EAN-13 will be scanned at POS.

### **Important Notes REGARDING TRADE ITEM ATTRIBUTE INFORMATION:**

- Attribute information cannot stand-alone; it must always be accompanied by a GTIN
- Attribute information can be encoded with the GTIN in a GS1-128 or GS1 DataBar<sup>1</sup> Bar Code. It can also be added as an additional bar code to an existing EAN-13, UPC-A, ITF-14 or a GS1-128 Bar Code, which is representing a GTIN
- If an AI appears on the same item more than once (e.g. if two labels are applied to the same item) the AI must be followed by the same information on each label
- Attribute information cannot currently be scanned at the retail Point-of-Sale<sup>1</sup>

<sup>1</sup> GS1 DataBar has been approved for bilateral use between trading partners from 2010 and, in 2014 GS1 DataBar becomes an open Symbology and all scanning environments must be able to read these symbols.



Of particular interest within the Consumer Electronics Industry is the identification of components of a trade item consisting of several parts. Within the GS1 System there is the ability to identify the components of an item to ensure all parcels are received.

**Note:** Consultation with your trading partners is essential if the use of this particular application is required as not all trading partners may yet be able to cater for this application.

The Component of a trade item AI (**8006**) identifies a parcel, which is part of an item identified with a GTIN. In some industries (such as appliances), a unit intended to be sold to the final consumer may be composed of several physical parcels. This AI is marked on each individual physical unit of the same retail unit. In shipping or receiving applications, it ensures that all components of the same retail unit are present.

The data content consists of the following elements:

- GTIN-14: identification of the whole item (fourteen digits)
- relative number of the component within the assembly (two digits)
- total number of components in the assembly (two digits)

**Note 1:** This AI should NEVER be used on retail units, which may be sold separately

**Note 2:** The AI (8006) can never be associated with another GTIN and therefore can never appear with AI (01)

**Figure 4: Component of a Trade Item**

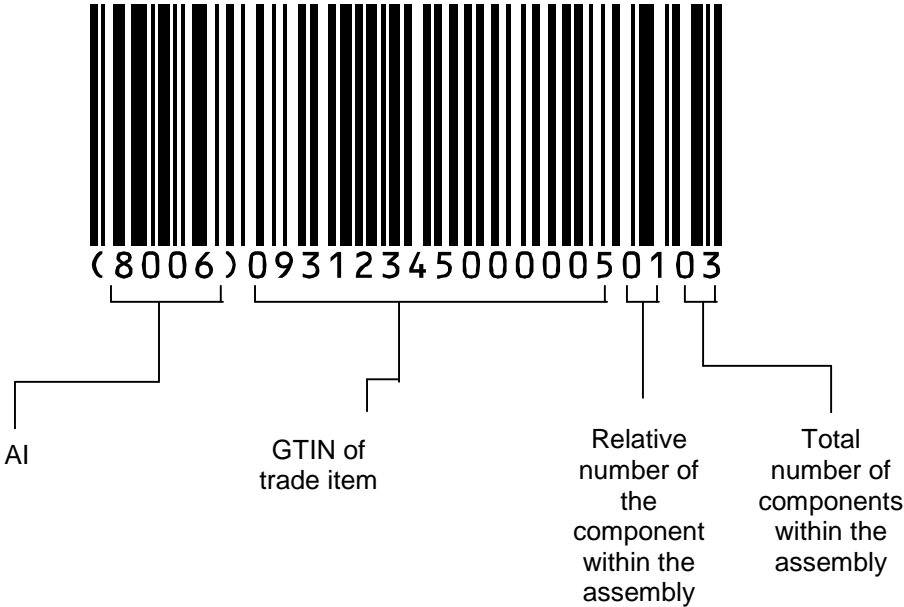

**For example:**

A home theatre system is sold with speakers as one single unit. However when distributed comes in multiple packages. To ensure all packages are received the following displays the use of the component of a trade item.

**Figure 5: Application of component of an item**

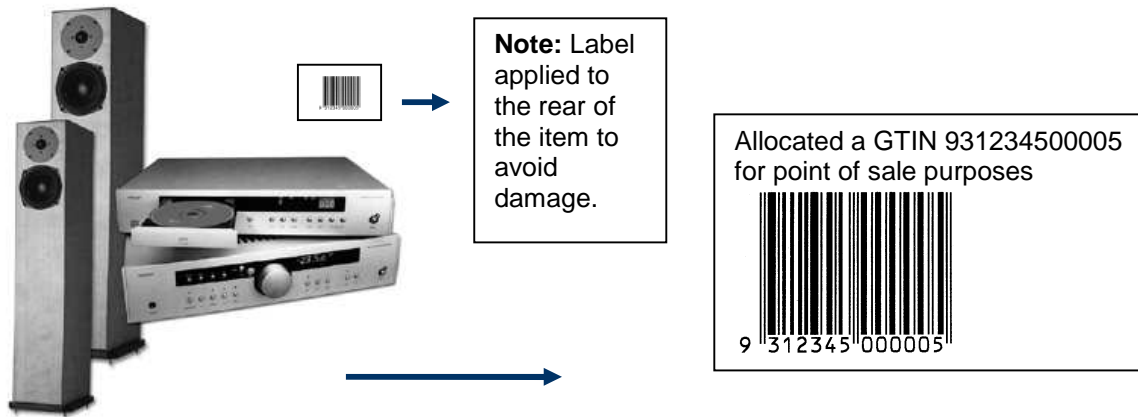

The home theatre system is then shipped in three packages:

- package one contains the main section of the unit
- package two contains the two speakers
- package three contains the CD player

Thus each unit would be marked as follows:

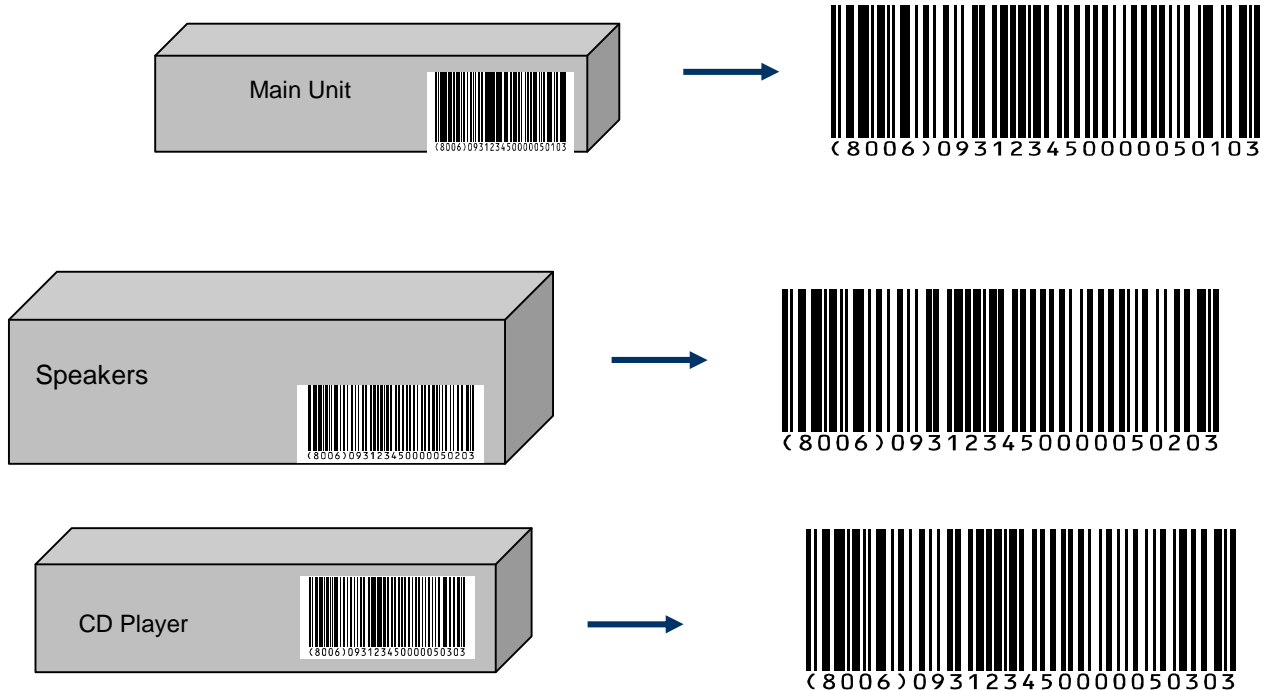

# 4.3 Difference between Numbering and Bar Coding

The GS1 System makes a clear distinction between numbering and bar coding. Even though they often go together, it is very important to be clear about the difference.

## 4.3.1 Numbering

The GS1 System provides Identification Keys (the 'Numbers') for different applications. The application will determine how the number is to be used. The data structure of the GS1 Identification Keys guarantees worldwide uniqueness within the relevant area of application. There are nine GS1 Identification Keys that support the identification of trade items, logistic units, shipments, consignments, locations, documents, service recipients, individual assets, and returnable assets. Each of the GS1 Identification Keys provides a link between the items and information pertaining to them.

## 4.3.2 Bar Coding

All of the GS1 Identification Keys ('numbers') used in the GS1 System can be represented in data carriers and of these, bar codes are the most commonly used. Bar codes are a means of representing data in machine readable form, and allow automatic data capture at each point where an item leaves or enters premises.

With improvements in the technology and new application requirements, new data carriers such as GS1 DataBar, GS1 DataMatrix, and EPC/RFID have been introduced.

Bar codes are usually included in the production process, at the producer site. They may be pre-printed with other information present on the packaging, a label can be affixed to the item at the production line, or they can be printed directly on to the packaging online.





For more information, please refer to the *GS1 Australia User Manual – Numbering and Bar Coding*.

Figure 6: GTIN-13 vs. EAN-13



## 4.4 Numbering, Bar Coding and packaging levels

**Table 1: Guide to choosing the numbering and bar coding options for a particular application**

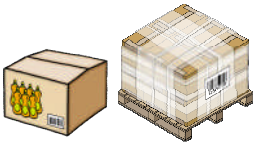
Application Areas	Encoded GTIN and/ or attribute information	Symbol
Retail Point-of-Sale only 	GTIN-13  GTIN-12 may be required for North America/Canada  GTIN-12 or GTIN-13 + attribute data <sup>2</sup>	EAN-13 (or GS1 DataBar <sup>3</sup> )  UPC-A (or GS1 DataBar <sup>3</sup> )  GS1 DataBar <sup>3</sup>
Retail Point-of-Sale only - small items 	GTIN-8  a zero-suppressed GTIN-12  GTIN-8 + attribute data <sup>2</sup>	EAN-8 (or GS1 DataBar <sup>3</sup> )  UPC-E  GS1 DataBar <sup>3</sup>
Retail Point-of-Sale and Non-Retail (General Distribution) 	GTIN-13  GTIN-12 may be required for North America/Canada	EAN-13  UPC-A
Non-Retail (General Distribution), ideal for printing on corrugate 	GTIN-13  GTIN-12  GTIN-14	ITF-14  ITF-14  ITF-14
Non-Retail (General Distribution), can encode attribute data, ideal for printing on labels 	GTIN-12, GTIN-13 or GTIN-14  GTIN-12, GTIN-13 or GTIN-14 + attribute data	GS1-128  GS1-128

**Note:** Depending on the Sector, there might be Industry specific requirements that need to be fulfilled (e.g. GS1 DataMatrix in the Healthcare sector).

<sup>2</sup> Attribute data will not be captured at the Retail Point of Sale, unless encoded in a GS1DataBar. Please refer to footnote 1 on page 8 for further information.

<sup>3</sup> see footnote 1 on page 8



Figure 7: an example illustrating Identification across the Supply Chain

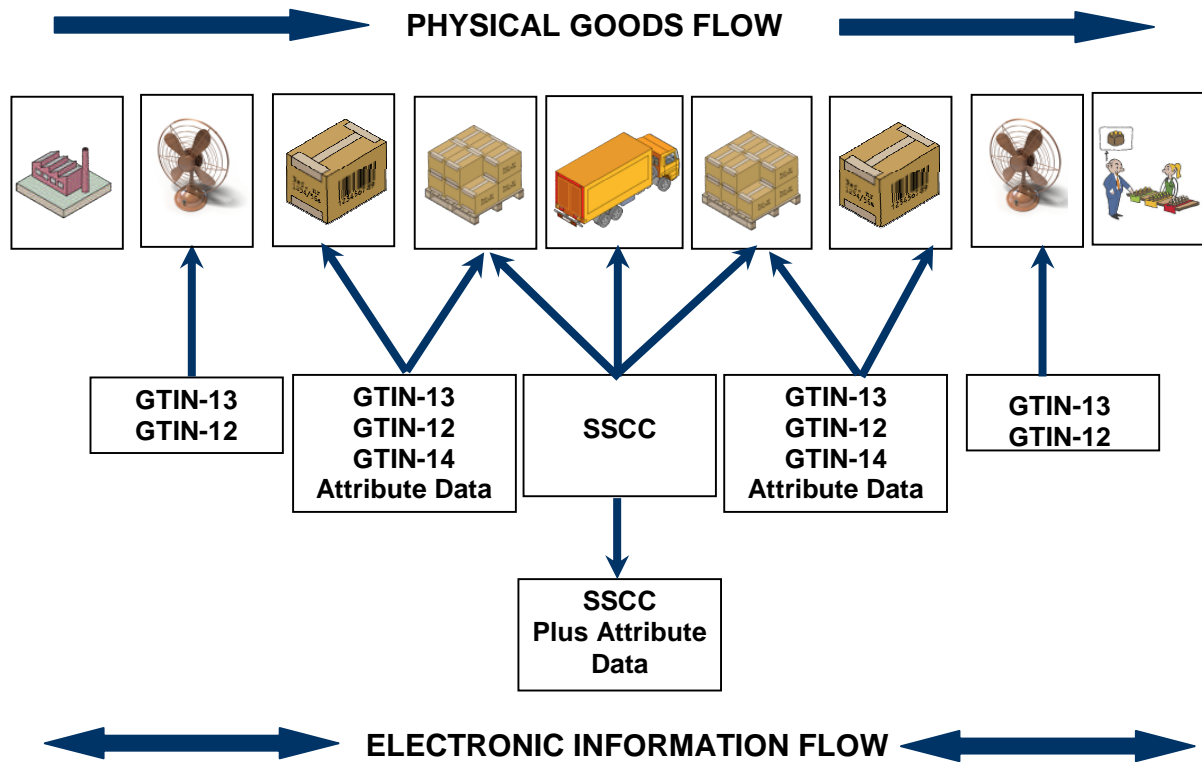

## 4.5 Fixed Measure Trade Items Sold at Retail Point-of-Sale (POS)

Any trade item which is intended to be sold to the final consumer through retail Point-of-Sale (POS) is more commonly known as a RETAIL ITEM or CONSUMER UNIT.

Trade items, scanned at retail POS can be identified with a GTIN-13, GTIN-12 or GTIN-8 as described in the following sections. To be scanned at the Point-of-Sale, these GS1 Identification Keys must be encoded in EAN-13, EAN-8, UPC-A, UPC-E or GS1 DataBar<sup>4</sup> Bar Code symbology.

### 4.5.1 GTIN-13

Trade items that are sold at POS are generally allocated a GTIN-13.

The format of the GTIN-13 is:

**GS1 Company Prefix:** The GS1 Company Prefix is allocated by GS1 Member Organisations. GS1 Australia allocates nine- or seven-digit GS1 Company Prefixes.

**Item Reference:** A unique non-significant number for each individual trade item. Generally issued sequentially, 000, 001, 002 etc for each different variant of a product.

**Check Digit:** Validates the accuracy of the entire number by mathematical formula.

A GTIN-13 can be represented in an EAN-13 or GS1 DataBar<sup>4</sup> Bar Code.

For details regarding the EAN-13 Bar Code, including dimensions, please refer to EAN-13 Bar Code specifications in the *GS1 Australia User Manual-Numbering and Bar Coding*.

**Figure 8: Example of an EAN-13 Bar Code representing the GTIN-13**

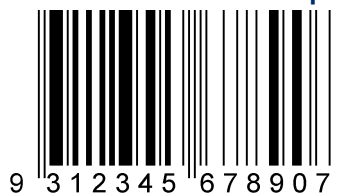

**Note:** Bar code size is not to scale.

**Figure 9: Example of a trade item carrying a GTIN-13 represented in an EAN-13 Bar Code**



**Note:** Bar code size is not to scale.

<sup>4</sup> see footnote 1 on page 8



## 4.5.2 GTIN-8

The allocation of a GTIN-8 is restricted to trade items that genuinely cannot accommodate a larger EAN-13 Bar Code. These can only be obtained directly from GS1 Australia and are allocated as a complete eight digit number. A GTIN-8 can be represented in an EAN-8 or GS1 DataBar<sup>5</sup> Bar Code.

For details regarding the EAN-8 Bar Code, including dimensions, please refer to EAN-8 Bar Code specifications in the **GS1 Australia User Manual-Numbering and Bar Coding**.

**Figure 10: Example of an EAN-8 Bar Code representing the GTIN-8**



**Note:** Bar code size is not to scale.

## 4.5.3 GTIN-12

If your trade item is to be sold within the United States and/or Canada, a GTIN-12 may be required. A GTIN-12 can be represented in a UPC-A or GS1 DataBar<sup>5</sup> Bar Code.

For more information on the GTIN-12 and for details of the UPC-A Bar Code, including dimensions, please refer to the **GS1 Australia User Manual – Numbering and Bar Coding**.

**Figure 11: Example of a UPC-A Bar Code representing the GTIN-12**



**Note:** Bar code size is not to scale.

## 4.6 Variable Measure Trade Items Sold at Retail Point-of-Sale (POS)

These Variable Measure Trade Items are those sold in random quantity against a fixed price per unit quantity and intended to cross a Point-of-Sale (e.g. apples sold at a fixed price per kilogram); the items are either marked in the store by the retailer or are marked at the source by the supplier.

There is currently no global solution for Variable Measure Trade Items sold at POS but work is underway to develop global standards for these items, particularly in the area of Fresh Foods.

There is, however, a **national** solution for Variable Measure Trade Items sold at POS; manufacturers who wish to label and apply bar codes to Variable Measure Trade Items must apply to GS1 Australia for standard variable measure company items numbers. The latter are used to construct a 13-digit number known as a VMN-13 (Variable Measure Number). For details on VMN-13s and the EAN-13 Bar Code in which they are encoded, please refer to the **GS1 Australia User Manual – Numbering and Bar Coding**.

---

<sup>5</sup> see footnote 1 on page 8



# 4.7 Fixed Measure Trade Items Non-Retail (General Distribution)

## 4.7.1 Definition

Trade items not sold at POS are any standard grouping of items made up to facilitate the operations of handling, storing, order preparation, shipments etc and may often be referred to as **NON-RETAIL TRADE ITEMS**.

It is recognised that beyond the trade item sold at retail POS, there can be many different levels of packaging of trade items. The next level of packaging, which is not likely to be sold at retail POS, is often referred to as an **INNER OR INTERMEDIATE** pack. The last level of packaging (the outer most) is considered to be the highest level; this is up to but not including the pallet. However, this does not preclude suppliers from issuing GTINs to pallets if they wish to identify the pallet itself as a trade item.

**Note:** Each individual level of trade item must be uniquely identified with a different GTIN

## 4.7.2 Options for Trade Items NOT sold at Retail Point-of-Sale (POS)

A trade item **not** sold at retail POS can be numbered and bar coded with:

- GTIN-14 represented in either the ITF-14 or GS1-128 Bar Code
- GTIN-13 represented in an EAN-13, ITF-14 or GS1-128 Bar Code

**For items sold in North America, refer to the *GS1 Australia User Manual-Numbering and Bar Coding*.**

### 4.7.2.1 GTIN-14

This option is only available for homogenous groupings of standard trade items, where all units contained in the group are identical. It involves using an Indicator with the GTIN and recalculating the Check Digit.

An Indicator can be any number from one to eight. Indicators are used to create up to eight unique GTIN-14s to distinguish between different packaging levels or pack quantities of the same trade item. They are chosen at the discretion of the company allocating the number.

**Note:** The Indicator 9 is reserved for variable measure trade items (see Section 4.5)

### How to form a GTIN-14 if a Trade Item Sold at Retail Point-of-Sale (Retail Trade Item) Carries a GTIN-13

Choose the GTIN-13 on the retail unit that is the lowest level of packaging within the non-retail trade item. To form the GTIN-14, put an Indicator in front of the first twelve digits of this GTIN-13 then recalculate the Check Digit. A Check Digit Calculator Program is available on our website [www.gs1au.org](http://www.gs1au.org).

Figure 12: structure of GTIN-14 based on GTIN-13

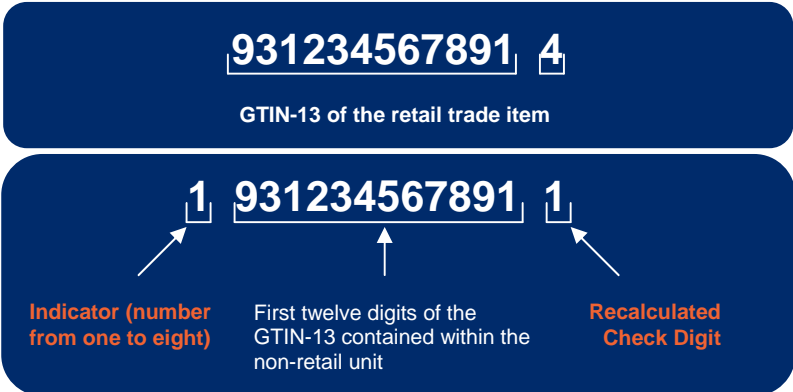

## How to form a GTIN-14 if a Retail Trade Item Carries a GTIN-8

Choose the GTIN-8 on the retail unit that is the lowest level of packaging within the non-retail trade item. To form the GTIN-14, put an Indicator followed by five filler zeros in front of the first seven digits of the GTIN-8 then recalculate the Check Digit. A Check Digit Calculator Program is available on our website [www.gs1au.org](http://www.gs1au.org)

Figure 13: structure of GTIN-14 based on GTIN-8

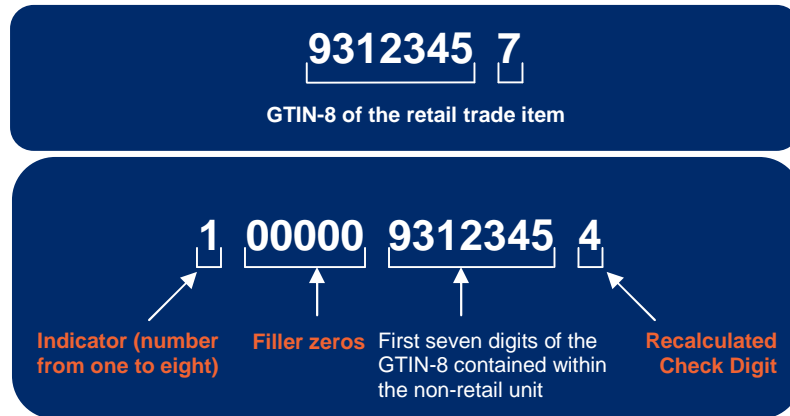

**Note:** The GTIN-14 can be represented in either an ITF-14 or a GS1-128 Bar Code but the ITF-14 Symbology is better suited for printing onto corrugated fibreboard.

Table 2: example of GTIN-14 created out of GTIN-13 or GTIN-8

Item		GTIN	Bar Code
Consumer unit/retail item		931234500000 5	EAN-13
		9312345 7	EAN-8
Box of 20 identical retail items		1 931234500000 2 1 000009312345 4	GS1-128 / ITF-14
Box of 50 identical retail items		2 931234500000 9 2 000009312345 1	GS1-128 / ITF-14

**Note:** Only allowed with identical products in the non-retail item.

Figure 14: ITF-14 Bar Code

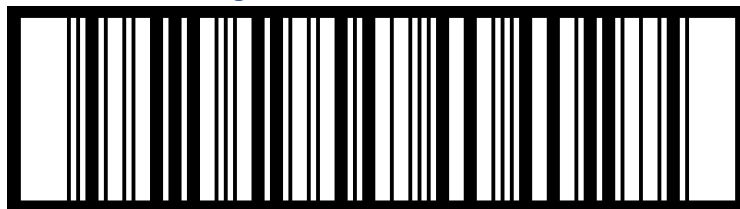

19323450000030

Figure 15: GS1-128 Bar Code

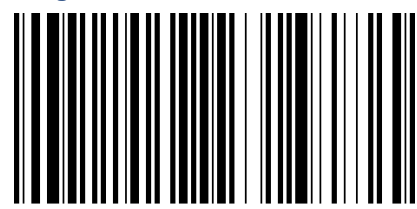

(01)19312345678904

**Note:** Bar code size is not to scale.



### 4.7.2.2 GTIN-13

If desired, a GTIN-13 can be allocated to a non-retail trade item. The method used to allocate this number is the same as for allocating a number to a retail trade item; refer to the **GS1 Australia User Manual - Numbering and Bar Coding**, located on our website - [www.gs1au.org](http://www.gs1au.org).

If there is any possibility of the non-retail trade item being sold at retail level, it *must* carry a GTIN-13 represented in an EAN-13 Bar Code. Ensure that a non-retail trade item is not allocated the same GTIN as a retail trade item.

If the non-retail trade item is NOT crossing Retail Point-of-Sale, it can be encoded in an ITF-14 or GS1-128 Bar Code, provided that a filler zero is added in front of the GTIN-13.

**The ITF-14 Symbology is better suited for printing onto corrugated fibreboard.**

**Figure 16: EAN-13 Bar Code**



**Figure 17: ITF-14 Bar Code**

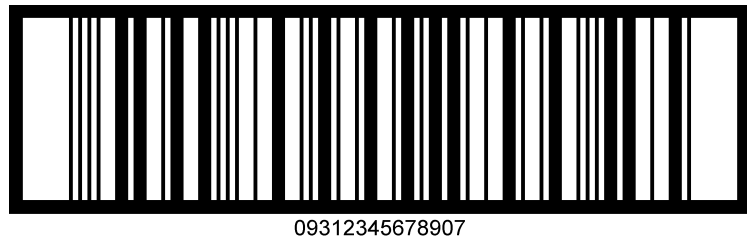

**Figure 18: GS1-128 Bar Code**

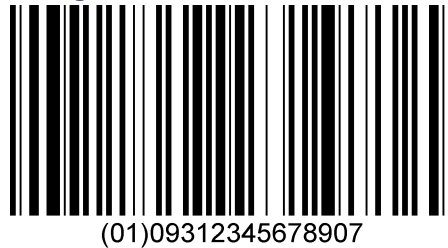

**Note:** Bar code size is not to scale.



## 4.8 Variable Measure Trade Items NOT Sold at Retail Point-of-Sale (POS)

Trade items may be of variable measure either because the production process does not guarantee consistency in weight, size or length (carcasses of meat, lengths of timber etc) or because the items are created to meet a special order which states a quantity (e.g. textiles ordered by the meter, glass ordered by the square metre).

Only trade items that are sold, ordered or produced in quantities, which can vary continuously, are covered by the rules outlined below. Trade items, which are sold in discrete and pre-defined units (e.g. as a nominal weight), are treated as fixed measure trade items.

A trade item must be considered to be variable measure if one of its parameters is variable and the variation is of significance to trading partner(s). For example, a supplier may sell and invoice timber in standardised bundles of a total of 10 metres, but the number of pieces of timber may vary. The customer, a retailer in this example, may need to know the exact number of pieces of timber contained in each bundle. In this example, the supplier should mark the trade item by using a variable measure GTIN and a variable count AI.

The GTIN-14 formed with the Indicator “9” is used to identify a Variable Measure Trade Item. The presence of variable measure information is mandatory for the complete identification of a particular Variable Measure Trade Item. The digit “9” in the first position is an integral part of the fourteen digit Variable Measure GTIN.

**Note:** Variable measure information represented in the following manner **cannot** be scanned at the retail Point-of-Sale (POS).

The format of one example of a variable measure GTIN-14 is:

<b>Application Identifier (01)</b>	Used to identify that the data following is a fourteen-digit GTIN when encoded in a GS1-128 Bar Code
<b>Indicator “9”</b>	Indicates that the trade item is of variable measure
<b>GS1 Company Prefix:</b>	The GS1 Company Prefix is allocated by GS1 Member Organisations. GS1 Australia allocates nine- or seven-digit GS1 Company Prefixes.
<b>Item Reference:</b>	Item Reference allocated by the company to each different item.
<b>Check Digit:</b>	Calculated using a mathematical formula
<b>Application Identifier (3111)<sup>6</sup></b>	Used in a GS1-128 Bar Code to identify that the information following is the length or first dimension in metres. The last digit, 1, of the AI indicates that the decimal point is located one place to the left of the end of the six digit number.
<b>Format</b>	Six fixed numeric characters used to represent the length in metres

**Figure 19: GS1-128 Symbol representing a Variable Measure Trade Item with a length of 2.5 metres**



**Note:** Bar code size is not to scale. For further information on Application Identifiers consult the *GS1 Australia User Manual - Numbering and Bar Coding*.

<sup>6</sup> The Application Identifier (3111) has been used as an example. Any of the measure AIs available can be used.



## 4.9 Location of the Bar Code on Trade Items

Productivity and scanning accuracy improve considerably when the bar code location is predictable. Consistency in the location of the bar code achieves maximum productivity in any scanning environment.

### 4.9.1 Trade Items Sold at Retail Point-of-Sale (POS)

Where the trade item sold at retail POS is to be bar coded, the **general** location for bar codes on trade items is the lower right quadrant of the back respecting the Quiet Zones around the bar code and the edge rule.

The **edge rule** stipulates that the bar code must not be closer than 8mm or further than 100mm from any edge of the package/container.

In the event that trade items are of an irregular or unusual shape, a common sense approach should be taken; the bar code should be located as close as possible to the recommended guidelines thereby ensuring that its location does not affect its ability to be scanned.

More detailed guidelines for specific types of retail trade items can be found in **GS1 Australia User Manual - Numbering and Bar Coding**.

#### 4.9.1.1 Large, Heavy or Bulky Items

The preferred placement of bar codes on items of a bulky nature such as White Goods, Large Televisions and Stereos is the following:

Any item weighing more than 13kg or having two dimensions greater than 450mm width/height, width/depth or height/depth is considered a large heavy or bulky item. Large, heavy or bulky items tend to be difficult to handle. The recommendation is two symbols, **one on the top and one on the bottom of opposite quadrants of the item**.

In all cases at least one bar code should be visible when products are placed on pallets and care should be taken to locate the bar code where the least amount of damage occurs to the bar code due to folds in the packaging.

Any other alternate locations should be discussed between trading partners.

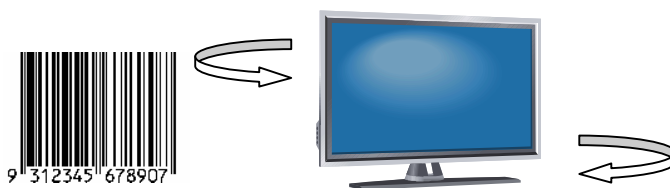

Note: Bar Code size is not to scale.

#### 4.9.1.2 Multipacks

Single items are sometimes packaged together as a trade item. This is referred to as a multipack. Multipacks provide convenience to the consumer and/or may represent a price reduction compared to purchasing items individually. Typical multipacks contain video cassettes, audio cassettes or batteries. To avoid confusion at the retail point of sale, the bar code printed on the multipack should be the **only** visible bar code when both the multipack and individual items are bar coded.

The recommended location for the bar code is towards the lower right quadrant of the back, observing the edge rule.



## 4.9.2 Trade Items NOT Sold at Retail Point-of-Sale (POS)

The bar codes on units not intended for retail POS should be upright (i.e. in picket fence orientation) and placed on the sides of the unit. Each item shall have at least one bar code, with two or more highly recommended. The bar codes should be kept away from any vertical edges so that they are less likely to be accidentally damaged in transit.

### **ALL ATTEMPTS SHOULD BE MADE TO MAINTAIN 100% SCANNABILITY AT ALL TIMES.**

The bar codes can be positioned anywhere along the face of the carton ensuring that the following GS1 recommendations are followed:

- The lower edge of the vertical bars (not the bottom of the surrounding horizontal bearer bar of an ITF-14 Bar Code) are exactly 32mm from the lower edge of the base of the carton
- No part of the bar code (including the Bearer Bars on an ITF-14 Bar Code, and Quiet Zones is closer than 19mm to any vertical edge

**Figure 20: Location of an ITF-14 Bar Code on a Trade Item**

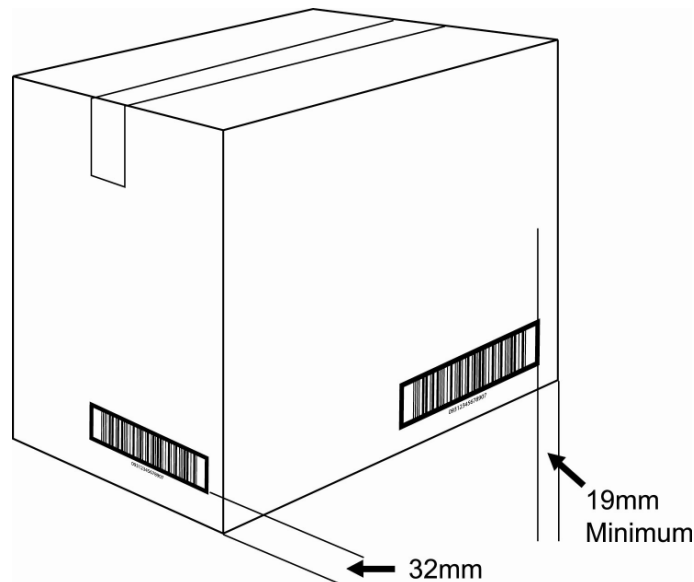

### ***Shallow Trays***

If the height of the non-retail unit is less than 50mm, making it impossible to print a full height bar code with the Human Readable Interpretation below the bars, or if the construction of the unit is such that the full height bar code cannot be accommodated, the following options should be considered (in order of preference):

- Place the Human Readable Interpretation to the left of the bar code, outside the Quiet Zones as shown in Figure
- When the height of the unit is less than 32 mm, the bar code may be placed on the top of the package, with the bars perpendicular to the shortest side, no closer than 19mm from any edge

**Figure 21: Symbol Placement on Shallow Trays**



# 5 How to Number and Bar Code Logistic Units

## 5.1 Serial Shipping Container Code (SSCC)

A logistic unit is an item of any composition established for transport and/or storage, which needs to be managed through the supply chain.

There are also instances within the Consumer Electronics Industry where the allocation of a GTIN is not feasible because the resulting permutations and combination of product is limitless and is generally governed by the customer’s order. Custom built computer systems fall into this category; with customers able to pick and choose what is required within their order and hence the allocation of a GTIN for each combination is unrealistic. With the use of scan packing, the solution for the marking of such a logistic unit is with the Serial Shipping Container Code (SSCC).

The Serial Shipping Container Code (SSCC) is a reference number or license plate used to uniquely identify logistics units. The SSCC acts as a “reference key” which can be stored in a computer system to which information can be added and shared amongst trading partners as the logistics unit moves throughout the supply chain. This unique “license plate” provides the opportunity to track and trace logistic units in the supply chain.

Scanning the SSCC marked on each logistic unit allows the physical movement of units to be individually tracked and traced by providing an information flow. It also opens up the opportunity to implement a wide range of applications such as cross docking, shipment routing, automated receiving etc.

The SSCC is used to uniquely identify goods on the way from sender to final recipient, and can be used by all participants in the transport and distribution chain. Each shipping container or logistic unit, at the time of its creation, is uniquely identified by the sender with an SSCC. A label encoding the SSCC is applied to the logistic unit using the appropriate AI and the GS1-128 Bar Code.

The SSCC uniquely identifies the entity (typically the shipping container or logistic unit to which the SSCC is applied) for the lifetime of that unit.

**Figure 22: The Use of the SSCC throughout the supply chain**

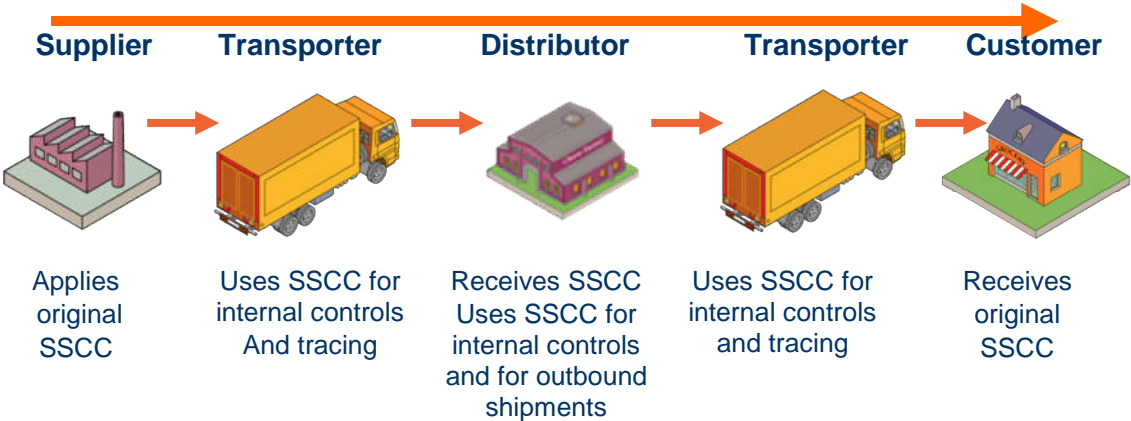

It is essential that the recipient, transport company, distributor or customer of the transport unit with the SSCC attached, receives prior advice about the details of the transport unit and the SSCC. This advice is usually communicated via eMessaging, which is the computer-to-computer exchange of business messages in a standard format.



There may be instances where all parties relevant to a particular shipment are not fully capable of eMessaging and where only some electronic messages are being exchanged. In this situation there may be a requirement to add additional information to the logistics label to facilitate the process of the logistic units through the supply chain. Alternatively the whole supply chain may be fully capable of eMessaging and the whole suites of shipping messages are being exchanged.

## 5.2 How to Allocate the Serial Shipping Container Code (SSCC)

The SSCC should be handled as an *eighteen digit non-significant number* uniquely identifying the unit to which it is attached. To ensure worldwide uniqueness, the following general code structure has been defined by GS1 Global Office:

The company responsible for the marking of the logistic unit is responsible for issuing the SSCC.

The format of the Serial Shipping Container Code is:

**Figure 23: structure of the SSCC**



**Table 3: structure of the SSCC**

<b>Application Identifier (00)</b>	Used in the GS1-128 Bar Code to identify that the data following is an eighteen-digit Serial Shipping Container Code (SSCC)
<b>Extension Digit</b>	A digit (0-9) used to increase the capacity of the Serial Reference within the SSCC. The company that constructs the SSCC assigns the extension digit to the logistic unit.
<b>GS1 Company Prefix:</b>	The GS1 Company Prefix is allocated by GS1 Member Organisations. GS1 Australia allocates nine- or seven-digit GS1 Company Prefixes. It makes the SSCC unique worldwide but does not identify the country of origin of the unit.
<b>Serial Reference:</b>	A Serial Reference usually comprises seven digits (nine digits if the GS1 Company Prefix is seven digits) and uniquely identifies each transport package or logistic unit. The method used to allocate a Serial Reference is at the discretion of the company coding the package.
<b>Check Digit:</b>	Calculated using a mathematical formula.

**Figure 24: Serial Shipping Container Code (SSCC)**



**Note:** Bar code size is not to scale.



## 5.3 The Logistics Label

The various trading partners involved in a distribution channel have different information needs. The information flow, which accompanies the physical flow of goods, is communicated between trading partners by various means. Electronic Commerce, or eMessaging, is the way to transmit information along the supply chain.

In practice, however, fully automated communication channels, which make it possible to rely exclusively on electronic files for retrieving information on the movements of goods, are not always available.

For this reason, there is a need to indicate relevant information on the goods themselves, in addition to their identification. The various fields of information need to be organised in a standard way in order to facilitate their interpretation and processing by all trading partners in the supply chain.

The purpose of the GS1 Logistics Label is to provide information about the unit to which it is fixed, clearly and concisely. The core information on the label should be represented both in machine (bar code) and human readable form. There may be other information, which is represented in human readable form only.

This GS1 Logistics Label can be applied to a single item, or a grouping of several items made up to facilitate the operation of handling, storing and shipping. This can be:

- A carton
- A pallet
- A group of shrink wrapped units
- A tray
- A container
- Or any other similar type of packaging created for the purpose of handling, storing or shipping.

The following information is a reference for the design of logistics labels. Application Identifiers (AIs) and the GS1-128 Symbology are important components of logistics labels and apply to all of the specifications relating to these labels.

The structure and layout for logistics labels is explained, however, emphasis is given to the basic requirements for practical application in an open trade environment. The major areas include:

- the unambiguous identification of logistic units
- the efficient presentation of text and machine readable data (bar codes)
- the information requirements of key partners in the supply chain– suppliers, customers and carriers
- technical parameters to ensure systematic and stable interpretation of the labels

This information is applicable to any type of logistic unit marked with a Serial Shipping Container Code (SSCC), which is used in logistic and transport applications where there is a need to track and trace individual units or a grouping of units being a part of the same transport transaction.

### 5.3.1 Components of the GS1 Logistics Label

Information represented on GS1 Logistics Labels has two basic forms:

- Information required to be utilised by people—usually comprising text and graphics, e.g. to and from addresses
- Bar codes (machine readable form) – a secure and efficient method of conveying structured data

The human readable text allows general access to basic information at any point in the supply chain. However, both methods of information representation provide value to the GS1 Logistics Label and often co-exist on the same label.



The mandatory field for all logistics labels is the Serial Shipping Container Code (SSCC) represented by the Application Identifier (00). The SSCC is a unique identification number assigned to each specific logistic unit. In principle the SSCC is sufficient for all logistic applications.

In an environment where eMessaging is used to transmit the detailed information pertaining to each logistic unit, or where the information is already within a database, the SSCC acts as the reference point to information.

However, when eMessaging is not available at each point in the supply chain, or when redundancy is desired, certain additional elements of information are desirable. Each of these is also represented through the use of Application Identifiers (AIs).

### 5.3.2 Label Design

The design of the logistics label accounts for the supply chain process by grouping information into three logical sections. A section is a logical grouping of information that is generally known at a particular time.

- **Supplier section:**  
This section of the label contains information that is generally known at the time of packaging by the supplier. The SSCC is applied here as the unit identifier, along with the GTIN if used. Other information that may be of interest to the supplier but might also be useful for customers and carriers can be applied. This includes product-related information such as product variant; dates such as production, packaging, expiration, and best-before dates; and batch/lot and serial numbers.
- **Customer section**  
The customer section of the label contains information that is generally known at the time of the order and order processing by the supplier. Typical information includes the ship to location, purchase order number, and customer-specific routing and handling information.
- **Carrier section**  
The carrier section of the label contains information that is generally known at the time of shipment and is typically related to transport. Typical information includes AI (420) - Ship-to Postal Codes, AI (401) - Global Identification Number for Consignment.

Each label section may be applied at a different point in time, as the relevant information becomes known. However should all relevant information be known at the time the label is to be produced, it can be combined into one label. Within each section bar coded information is separated from text information to facilitate separate processing by automatic data capture and people. Bar codes are represented in the lower part of each section, while human readable information is shown in the upper part of the section. This facilitates access to each component as required.

The organisation responsible for the printing and application of the label determines the content format and dimensions of the label.

Further information regarding the type of data included in these sections can be obtained from the **GS1 Australia User Manual - Numbering and Bar Coding**.

**Figure 25: Label sections represented separately on a logistic unit**

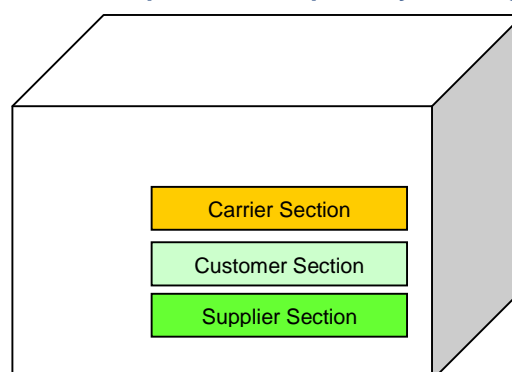

### 5.3.3 Label Dimensions

The physical dimensions of the label are determined by the company applying the label to the logistic unit. However, the size of the label should be consistent with the information required in all sections of the label.

The business requirements for most users of GS1 Logistic Labels are met by using one of the following:

- A6 format (105mm x 148mm) which is particularly suitable when only the SSCC, or the SSCC and limited additional data is encoded.
- A5 (148 mm x 210 mm)

### 5.3.4 Technical Specifications

The following sections identify specific aspects of the format of the logistics label to assist in the initial processes of development. Not all technical aspects have been provided within this document and companies should ensure that they consult the **GS1 Australia User Manual - Numbering and Bar Coding** or contact GS1 Australia for further information.

#### 5.3.4.1 Bar Codes

The GS1-128 Bar Code shall be used for all information on the GS1 Logistics Label.

The number of GS1-128 Bar Codes may be minimised by using concatenation (stringing data elements together) wherever possible. When not possible due to constraint of label size, data can be represented in multiple bar codes. The sequence of the bar coded data elements is irrelevant in terms of interpretation.

**Note:** The exception is the SSCC, which is the identifier for the logistic unit and the most fundamental element of the label. Due to the larger magnification recommended for the SSCC, concatenation is not feasible on a standard width label.

#### 5.3.4.2 Bar Code Orientation and Placement

Bar codes shall be in picket fence orientation on logistic units, i.e. the bars and spaces shall be perpendicular to the base on which the logistic unit stands. In all cases, the SSCC shall be placed in the lowest portion of the label.

#### 5.3.4.3 Text

There are three types of text information, which can appear on a logistics label:

- Plain text - text that is not encoded in the bar code but often required on a label e.g. name and address of the sender and receiver
- Human Readable Interpretation - the information encoded in the bar code that is required to support manual operations and to facilitate key entry.
- Data titles - the standard abbreviated descriptions of data fields used to denote the Human Readable Interpretation of data fields e.g. SERIAL is the data title of serial number.

Further details can be found in the **GS1 Australia User Manual - Numbering and Bar Coding**.



## 5.4 GS1 Logistics Label Formats for the Australian Consumer Electronics Industry

As described in Section 5.1 there is the ability to identify logistic units with the use of the Serial Shipping Container Code (SSCC). Where companies and/or industry sectors are not fully capable of eMessaging there is often a need to identify additional data represented on the GS1 Logistics Label to assist processing of shipments through the supply chain.

The following section describes the minimum data set required on a GS1 Logistics Label for the Australian Consumer Electronics Industry for use on logistic units of the following configuration:

- **Logistic unit containing the same trade items** (see Figure 26)  
This label format would be used in the instance where the trade items carry the same GTINs within the logistic unit. Data on this label is only applicable where the GTINs are all the same on the individual trade items, for example a pallet of 20 cartons of nails.
- **Logistic unit containing the same configuration of trade items** (see Figure 27)  
In the event that the logistic unit itself has been assigned a unique GTIN this label example can be used. This label format should be used when the trade item is a standard, stable and orderable trade item in itself. The logistic unit could consist of either a standard grouping of identical trade items or a standard mix of trade items.
- **Mixed trade items on the logistic unit from the same Purchase Order** (see Figure 28)  
When an order is picked and packed and is a mix of various trade items from one Customer Purchase Order this label format can be used.
- **Mixed trade items on the logistic unit from various Purchase Orders** (see Figure 29)  
In the event that a back order/s is filled thus consisting of various Customer Purchase Orders this example logistics label is required. Note full use of eMessaging is required to advise the customer of the information linked to the SSCC.
- **Where full eMessaging is applicable** (See Figure 29)  
In this example full use of eMessaging is applicable between trading partners. Here all the information is linked to the SSCC and this acts as the key to access all information about the logistic unit. This label format can be used on all types of logistic units from, standard groupings to mixed trade items. The only requirement is that eMessaging is fully operational between all trading partners throughout the supply chain.

**Note:** Information contained on the GS1 Logistics Label is negotiable between suppliers, customers and transporters/consolidators. These guidelines in no way limit any other information, which may be required by each party in the supply chain.

**Note:** The bar codes in Figure 26 to Figure 29 are not to scale.



Figure 26: Example of the GS1 Logistics Label Format standard pallets

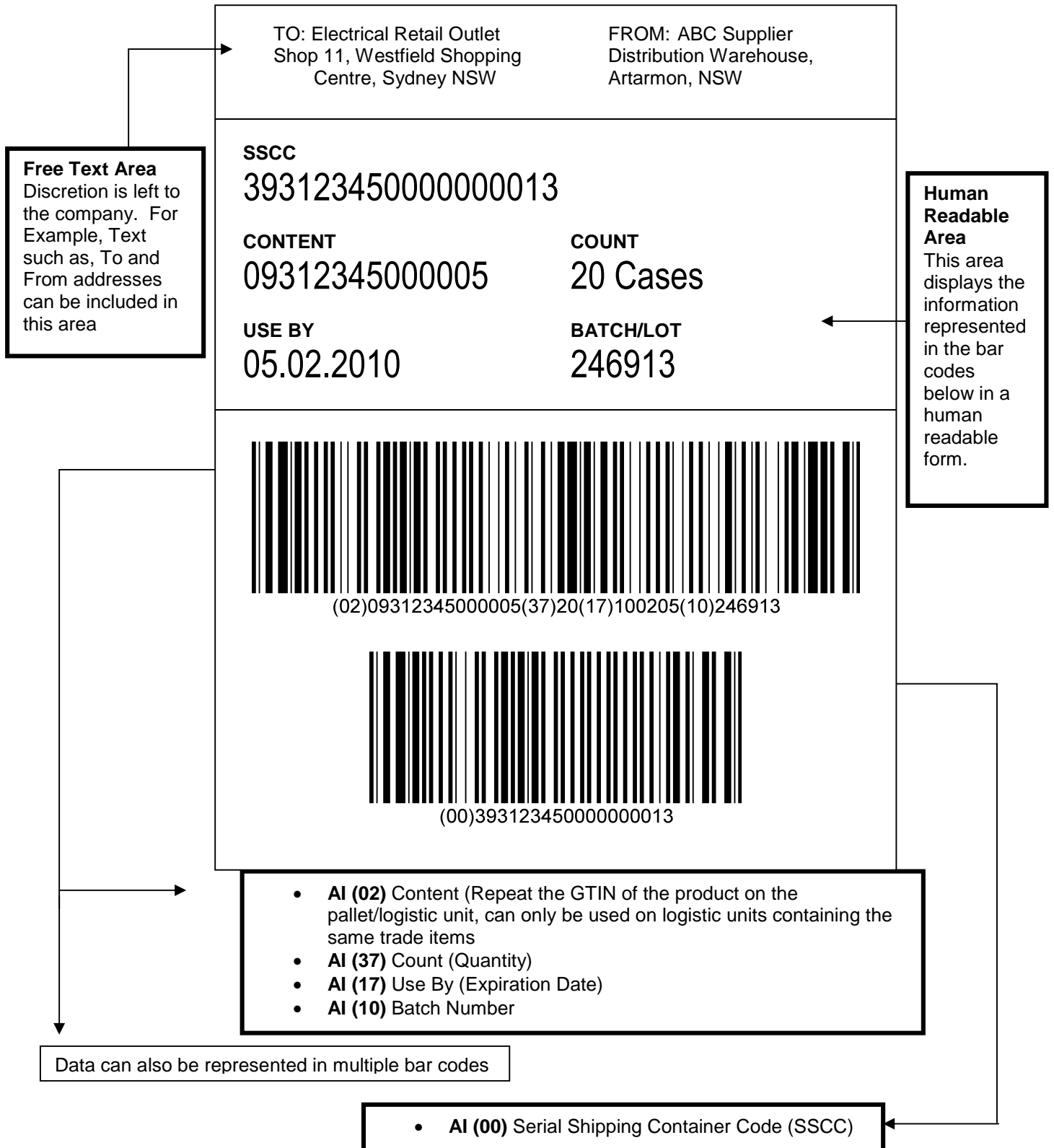
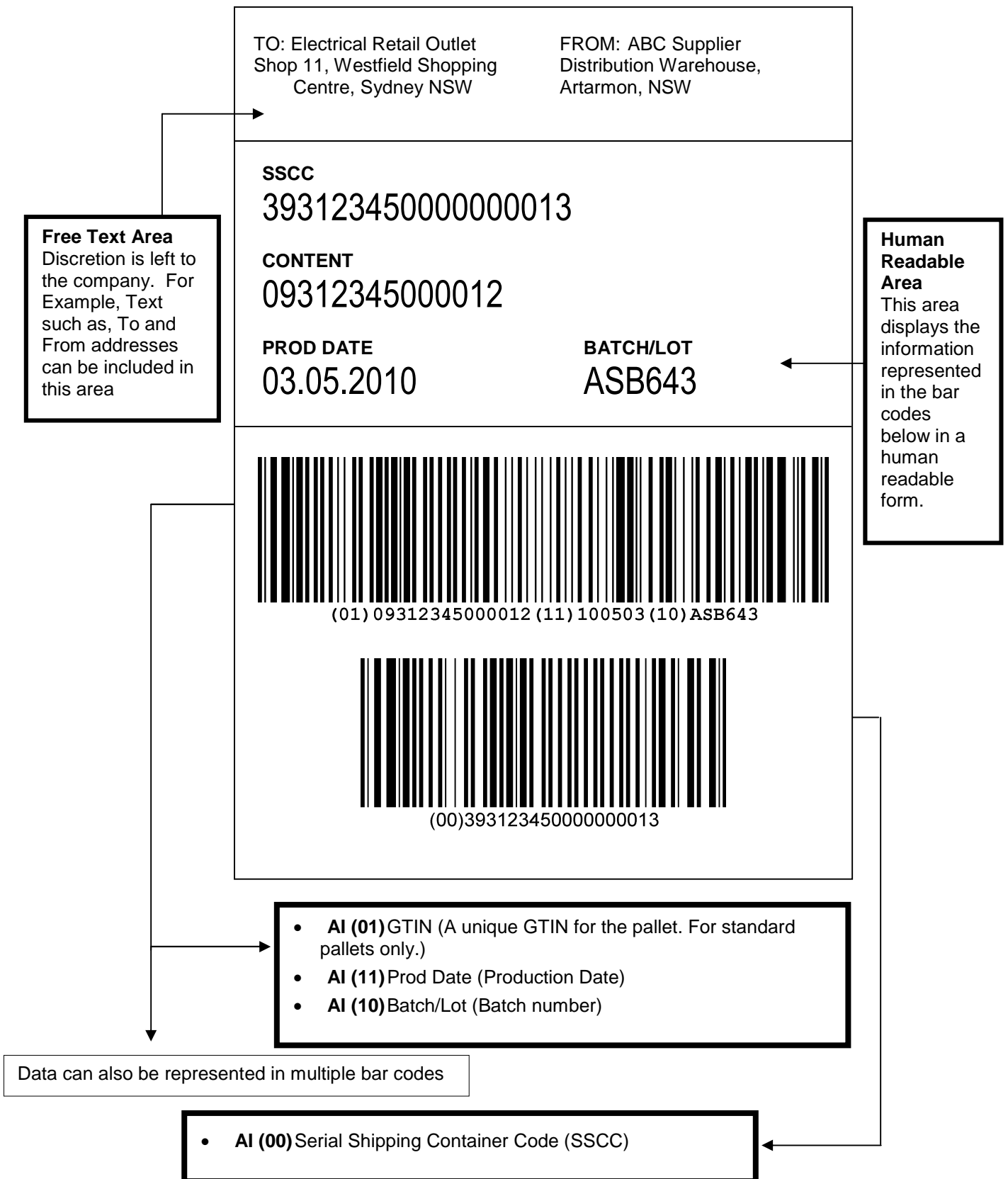
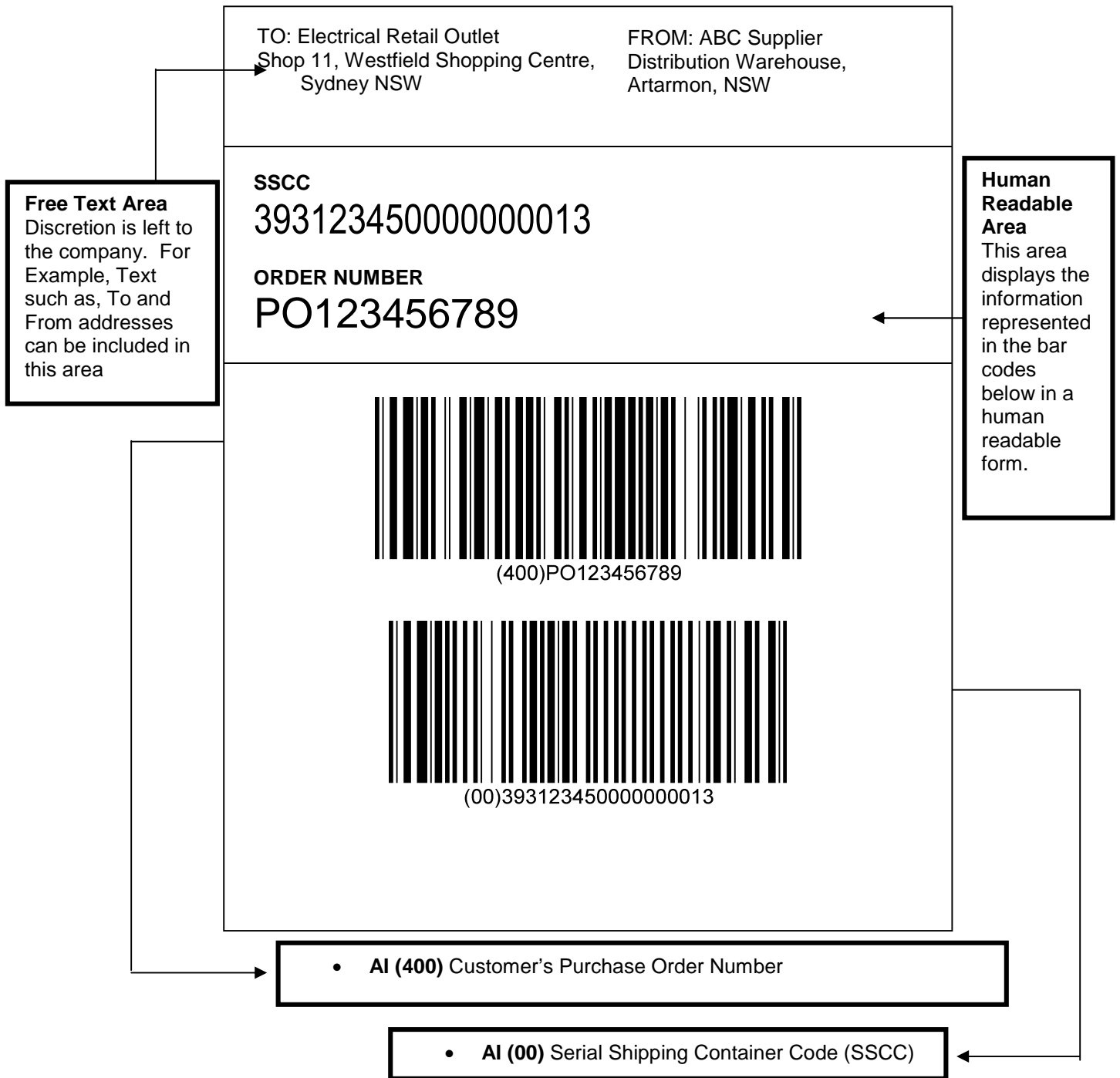

Figure 27: Example of the GS1 Logistics Label Format standard pallets



**Figure 28: Example of a GS1 Logistics Label Format mixed orders same Customer Purchase Order**



**Figure 29: Example of a GS1 Logistics Label Format mixed trade items with different Customer Purchase Order Numbers**

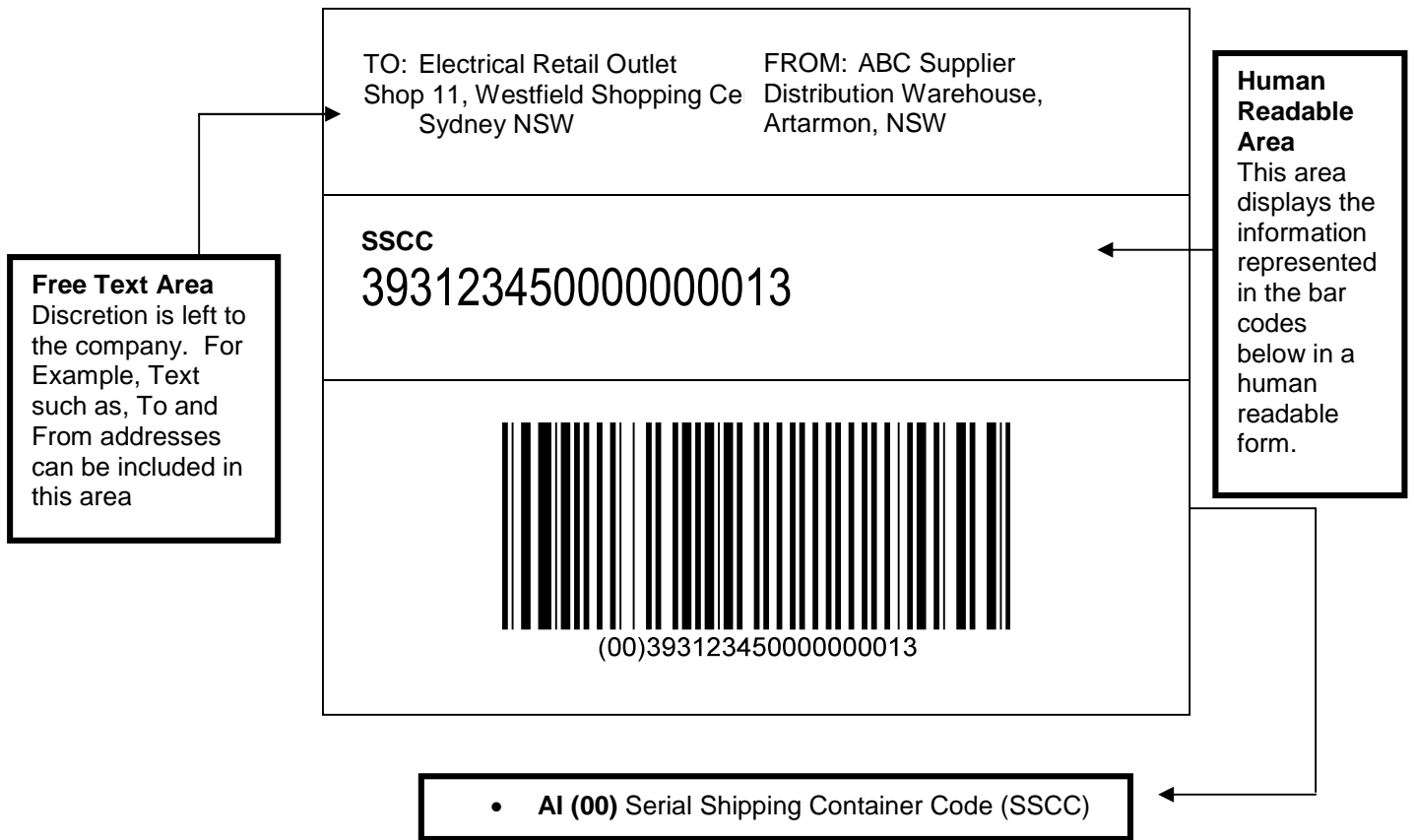

**Note:** Full use of eMessaging is required when using the above label format to advise the trading partner of the information linked to the SSCC.



## 5.5 Location of Logistic Unit Label

The bar codes on units intended for General Distribution should be upright (i.e. in picket fence orientation) and placed on the sides of the unit. Each item shall have at least one bar code, and two are recommended.

In the event that the product is not a standard carton or pallet of uniform shape all efforts should be made to meet the recommendations. For shipments with an irregular or unconventional shape common sense should direct the location of any logistics labels to ensure that the label is visible at all times.

**Note:** If only one label is applied, the side chosen needs to take into consideration the way the pallet will be picked. In this instance the label should be applied to the “pick side” of the pallet. Before taking this option, consultation with all trading partners is advised.

Consult the **GS1 Australia User Manual - Numbering and Bar Coding** or contact GS1 Australia for further information on logistic label location.

### 5.5.1 Cartons and Outer Cases

For cartons and outer cases, logistic labels should be placed so that the lowest edge of the vertical bars of the GS1-128 Bar Code containing the SSCC is 32mm from the base of the unit. Ensure that no part of the bar code (Including Quiet Zones) is closer than 19mm from any vertical edge.

**Figure 30: Location of the GS1 Logistics Label on a carton or unit less than 1 metre in height**

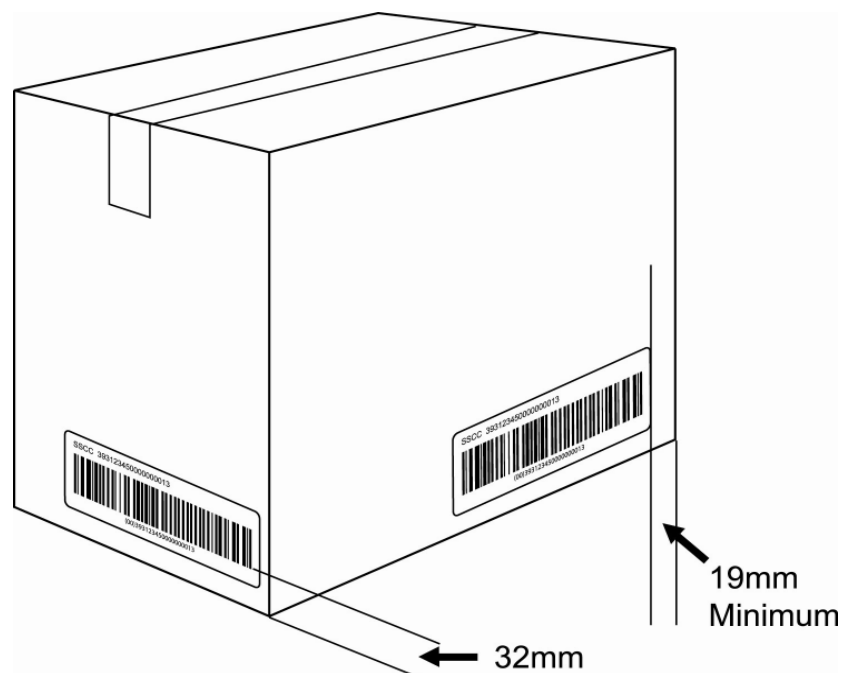

If the unit is already marked with an EAN-13, UPC-A, ITF-14 or GS1-128 Bar Code for trade item identification purposes, the label should be placed so as not to obscure the pre-existing bar code. The preferred location of the label in this case is to the side of the pre-existing bar code, so that a consistent horizontal location is maintained.



## 5.5.2 Pallets

For all types of pallets, including full pallets containing individual trade items and singular trade items (such as a fridge or washing machine), bar codes should be placed at a height between 400mm and 800mm from the base of the unit. Including Quiet Zones, the bar codes should be no closer than 50mm from any vertical edge to avoid possible damage.

For pallets less than 400mm in height, the bar codes should be placed as high as possible whilst protecting the logistics label.

**Figure 31: Location of the GS1 Logistics Label on pallets**

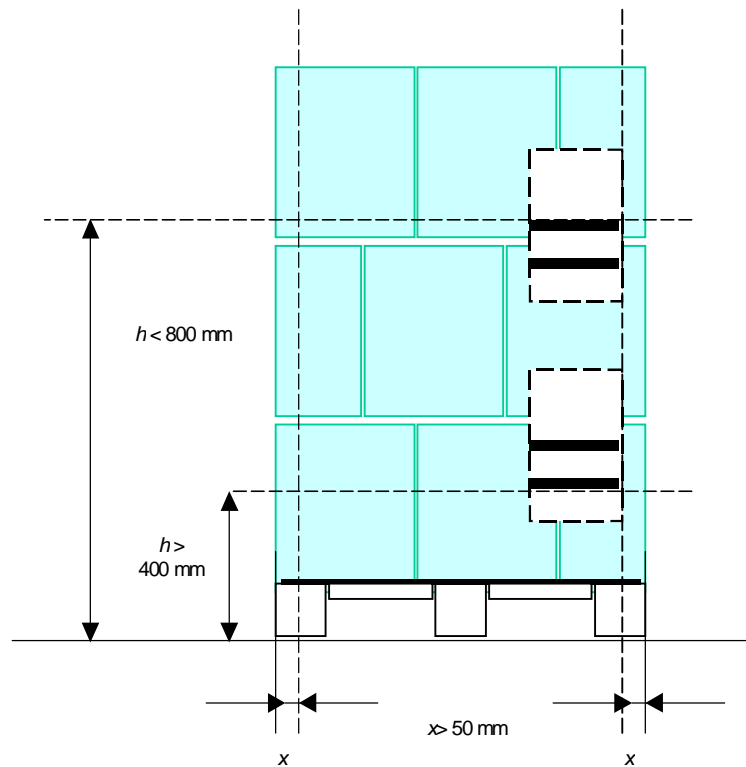

# 6 Global Location Numbers

## 6.1 Introduction

On a daily basis information related to parties and locations is generated and communicated throughout the business world in vast quantities. Names and addresses are put on envelopes for the mail, the point to which a delivery is to be made is put on transport documentation, EDI network addresses are provided in an electronic message, etc. These are just a few examples of the many applications in existence today, which identify parties or locations in trade or other communications.

With the advent of electronic communication, the need for the identification of parties and locations has become more acute. The use of numeric identification instead of full alphanumeric names and addresses is the key to the successful implementation of an eMessaging project.

Global Location Numbers (GLNs) offer an internationally recognised standard solution to the identification of parties and locations.

Once assigned at source, i.e. in general by the party owning the location, the GLN becomes a unique and universal reference, which can be used by all.

## 6.2 Definition of the Global Location Number (GLN)

The GLN is a thirteen-digit non-significant reference number used to identify:

- Legal entities, e.g. registered companies
- Physical entities, e.g. a door of a warehouse, a particular room in a building

Global Location Numbers (GLNs) can be used to identify anything which is, or can be, addressed. Some examples of this would include companies, departments, rooms, factories, shelves, delivery points, network addresses, etc.

Details associated with a GLN, e.g. name and address, location type, contact persons, communications numbers, banking information, delivery requirements or restrictions, etc., are stored in the computer files of the system for later retrieval.

Although a GLN is strictly a reference key and does not carry any information on the location it identifies, it has a standard format and is structured to allow each GLN to be unambiguous and unique worldwide.

The format of a GLN is a thirteen-digit, fixed length numeric field, structured in the same way as a GTIN-13.

GLNs are mainly used in eMessaging to identify the sender and recipient of an electronic transmission and any party relevant to the transaction, e.g. buyer, seller, carrier etc.

GLNs can also be used in a bar code format to identify a physical location or to encode the identification of relevant parties in logistic applications, e.g. "Ship-to" location number. The GS1-128 Bar Code is used to encode a GLN but a filler zero must be added to the front of the GLN to create a 14 digit number. In addition, the appropriate Application Identifier should be used according to the rules specified in the **GS1 Australia User Manual – Numbering and Bar Coding**.

GS1 Australia member companies that have been allocated a GS1 Company Prefix for item identification can use the same GS1 Company Prefix for assigning GLNs.



Companies that are not members of GS1 Australia can still use GLNs. These companies should contact GS1 Australia for further information.

## 6.3 Implementation Timing

- All companies should be identified by a GLN in all electronic messages.
- All locations (warehouse, stores, manufacturing plants, etc.) in electronic messages should be identified by GLNs.
- During a migration period, both GLNs and current internal numbers can be used at the discretion of the trading partners for identifying locations.



## 7 Asset Numbering

The GS1 System provides a method for the identification of assets. The object of asset identification is to identify a physical entity as an inventory item.

Asset Identifiers may be used for simple applications, such as the location and use of a given fixed asset (e.g. a personal computer), or for complex applications such as recording the characteristics of a returnable asset (e.g. a reusable beer keg), its movements, its life-cycle history and any relevant data for accounting purposes.

Within this guideline, Asset Numbering has not been covered in any more detail. If you require further information please consult the ***GS1 Australia User Manual-Numbering and Bar Coding*** or contact GS1 Australia.



# 8 Appendix

## 8.1 Bar Code Quality Check List

There are a number of aspects to printing the bar code to ensure that 100% readability is achieved and maintained. The checklist below itemises the things to check during the bar code generation and printing processes.

- Ensure that the correct bar code is used for the relevant product, application, and scanning environment
- Check that the bar code will remain readable in the environment in which the product will be stored, handled, and distributed
- Ensure that the Check Digit is correct
- Check the size of the bar code, both the magnification and the bar height
- Ensure that there are adequate Quiet Zones, and that any optional Quiet Zone Indicators are correctly placed
- Check that the contrast between the bars and the background is adequate, and that the colours chosen will scan
- Make sure that the colour of the contents of the packaging will not unduly affect the contrast between the bars and spaces
- Check the position of the bar code on the final, formed product
- Ensure that no shrink-wrap, tape, or other printing will obscure the bar code on the finished product
- Ensure that no other bar codes will be visible or show through from the inside of the pack
- Carry out routine verification at all levels of packaging to ensure that the bar code complies with the required quality standard, and to identify any potential problems
- Check the print quality regularly throughout the print run by verifying the bar code quality
- Notify trading partners of the GTINs and the products they identify in good time
- Consider having GS1 Australia prepare a Bar Code Verification Report on the artwork for you prior to the final print to help detect any errors or areas for improvement

Some in-house printing methods, particularly on-line ink jet printing, require attention to the total print process and on-going maintenance.

The GS1 specifications for printing bar codes are explicit in that if the specified procedures are followed, with routine quality control, you can produce bar codes that scan consistently.

**Note:** It is recommended that the quality of the bar codes be assessed. This can be achieved through the use of the GS1 Bar Code Verification Service. Please refer to section 8.3 for further information or contact GS1 Australia.



## 8.2 Emerging Technologies

### 8.2.1 EPC Network & Radio Frequency Identification (RFID)

Global trade involves moving goods and tracking them around the world. GS1 Global Office through their joint venture EPCglobal are rolling out and supporting adoption of the EPC network, which combines low cost RFID technology, existing communications network infrastructure and the Electronic Product Code (EPC). The EPC Network will make organisations more effective through real and timely visibility of information about items in the supply chain. The EPC network was developed by the Auto-ID Centre, a global research team directed through the Massachusetts Institute of Technology (MIT) and with labs around the world.

The EPC network incorporates global standardisation of tags and readers, a common method for describing objects Physical Markup Language (PML), middleware for the filtering and interpretation of data and an Object Naming Service (ONS) registry for locating the source of specific item information. Global standards have been developed with direct input from the GS1 community and end users.

The use of RFID technology has some advantages over linear bar codes in that;

- It does not require line of sight
- Multiple items can be read
- Some tags have read/write ability and have larger data storage capacity
- Some tags have additional functionality such as temperature monitoring

### 8.2.2 GS1 DataMatrix

GS1 DataMatrix is a standalone two-dimensional matrix symbology that is made up of square modules arranged within a perimeter finder pattern. Data Matrix has been used in the public domain since 1994.

Some of the production processes that can be used to produce GS1 DataMatrix Symbols are as follows:

- Direct part marking, such as is done by dot peening on items, such as automotive, aircraft metal parts, medical instruments, and surgical implants
- Laser or chemically etched parts with low contrast or light marked elements on a dark background (e.g., circuit boards and electronic components, medical instruments, and surgical implants)
- High-speed ink jet printed parts and components where the marked dots cannot form a scannable linear symbol
- Very small items that require a symbology with a square aspect ratio and/or cannot be marked with the allocated packaging space by existing GS1 DataBar (formerly RSS) and Composite Symbols (see footnote 1 on page 8)

GS1 DataMatrix symbols are read by two-dimensional imaging scanners or vision systems. Most other scanners that are not two-dimensional imagers cannot read GS1 DataMatrix. GS1 DataMatrix Symbols are restricted for use with new niche applications that will involve imaging scanners throughout the supply chain.



## 8.3 Services Offered by GS1 Australia

### 8.3.1 Introduction

A new era demands new solutions and new solutions demand new services. Consequently GS1 Australia has invested heavily in a series of initiatives geared toward helping members successfully implement eCommerce based supply chain management strategies.

Through our specialised member assistance divisions: Industry Management, Accreditation, GS1net and Professional Services, we are positioned to respond more efficiently to member needs.

By utilising these services as appropriate, you can gain greater control over your business and prepare for the future.

### 8.3.2 The Services

#### 8.3.2.1 *Industry Management*

The Industry Management Team provides assistance to GS1 Australia's Members, enabling them to equip themselves with the knowledge needed to adopt the GS1 Standards successfully.

Membership of GS1 Australia allows the use of the GS1 System for supply chain management and eCommerce processes.

It also provides you, the member, with a wide range of assist services, which include; assistance on how to apply numbers and bar codes, helpdesk support on GS1 System queries, onsite visits, advice on GS1 System implementation, industry guidelines and education & training.

As a member, you can call on the Industry Management Team as an invaluable resource for achieving greater control over day-to-day supply chain processes and business transactions.

As part of GS1 Australia's commitment to industry, Industry Management team is also responsible for the delivery of the 'Industry Engagement Program' that assists the industry wide adoption and education of the GS1 System. Currently GS1 works with eighteen industry sectors in Australia to improve supply chain efficiency between trading partners by utilising eCommerce and GS1 Global Standards.

#### 8.3.2.2 *Testing Services - Bar Code Verification Reporting*

GS1 Australia offers a bar code verification report service to all members. Bar codes are tested for print quality against ISO standards to ensure they will be able to be scanned successfully through the supply chain. We also test the validity of the number encoded and ensure it is unique to this product and within the brand owner's available allocation.

A full Bar Code Verification Report is issued for each test that confirms compliance and makes educational suggestions for improvement where applicable.

#### 8.3.2.3 *GS1net –Global Data Synchronisation Service*

Because integrity of data is crucial to eCommerce, GS1net has been developed as a secure on-line data synchronisation service, holding records of significant volumes of bar-coded items, including grocery, liquor, healthcare, hardware, auto aftermarket, general merchandise, office products and much more. Each record contains a broad range of fields that include product identifiers, images, description, dimensions, bar code testing status, customer specific pricing and trading terms.

The GS1net catalogue has been created to meet the following needs:

- Allow all trading partners to electronically synchronise data and remove errors associated with paper-based processes.
- Provide retailers, wholesalers, Healthcare jurisdictions and other industry stakeholders with an



inexpensive means of accessing information on available products and their master data attributes.

- Provide a single point of entry and retrieval data repository, to enable data integrity that is essential to minimising errors in eCommerce transactions.

Notably, GS1net has already been endorsed by major trading partners in the Australasian Healthcare, Grocery, Liquor and Hardware industries.

#### **8.3.2.4 Professional Services**

GS1 Australia members requiring additional onsite implementation support can benefit from GS1 Australia's Professional Services' expert and independent assistance. GS1 Professional Services provide dedicated consulting services covering all elements of the GS1 System for unique item identification, bar coding and RFID, electronic messaging and data synchronisation..

GS1 Professional Services' advisors offer a cost-effective and relevant means to come to terms with GS1 System processes and benefits. Professional Services can help you with all aspects of your implementation project, including:

- Project Planning, Management and Facilitation
- Business process analysis and design
- Selection of required hardware and software
- Development of functional specifications for systems integration
- Training and change management programs
- Compliance audits of internal processes, systems and applications to meet specific industry or trading partner requirements

GS1 Professional Services also offers a range of tailored programs designed to implement the GS1 System for internal operational improvements.

GS1 Professional Services' advisors not only have a deep technical understand of the GS1 System, but also have a wealth of implementation expertise across a number of industry sectors, including wholesale / retail, manufacturing, foodservices, automotive aftermarket, hardware, healthcare, liquor, building and agriculture. As a result, we can help to deliver complete end-to-end solutions by providing members with unbiased advice on hardware and software, facilitating implementation and training staff and management.

For more information on any of the above services, please contact GS1 Australia.

#### **8.3.2.5 GS1 Locatenet**

GS1 Locatenet is a central directory of GS1 Global Location Numbers (GLNs) which identify physical, operational and legal locations. GLNs may be assigned to pricing locations, ship-from locations, ship-to destinations, eMessaging addresses and more.

GS1 Locatenet delivers the ability for trading partners to communicate location master data using GS1 global standards. GS1Locatenet facilitates the dissemination of quality location data from a central, validated, electronic source, supported and administered by GS1 Australia.

Whilst developed initially for the Healthcare sector to support the National Product Catalogue (NPC), GS1 Locatenet is available to all users of GLNs, across all industries.

For further information on GS1 Locatenet, please visit <http://www.gs1au.org/services/locatenet/>

#### **8.3.2.6 GS1 Recallnet**

GS1 Recallnet is GS1 Australia's Recall & Withdrawal Notification Service.

GS1 Recallnet is a standardized, industry-driven communication tool enabling manufacturers to share real-time product recall and withdrawal notifications information with their trading partners in a secure and efficient manner.



This user-driven online tool is being developed through an industry consultation and collaboration process and is based on local and global best practices.

GS1 Recallnet enhances existing recall and withdrawal notification processes and leverages GS1 standards and GS1 keys, including Global Trade Item Number (GTIN), Global Location Number (GLN), Global Service Relation Number (GSRN), and the Global Document Type Identifier (GDTI).

For further information on GS1 Recallnet, please contact GS1 Australia on 1300 366 033.

### **8.3.2.7 Training Services**

Four different training modes make GS1 learning convenient even for the busiest of schedules. An array of education options and training sessions allows members to get the supply chain management education they need, regardless of where they live or when they are available.

Members can select from:

#### **8.3.2.7.1 Classroom Sessions**

Traditional classroom training sessions offer the opportunity to learn from expert instructors. Classes run throughout the day and allow new and existing members to gain better insight and understanding of the GS1 System.

#### **8.3.2.7.2 Online Courses**

For members who find it difficult to travel to a classroom, GS1 Australia training is as close as the internet. An online training tool, GS1 LEARN allows members to take a series of courses on essential supply chain concepts, anywhere and at their own pace, 24 hours per day, seven days a week.

#### **8.3.2.7.3 Web Interactive Training**

New members can take advantage of GS1's web-interactive training, or "webinars" for an introduction to the GS1 System and all the information and tools needed to print bar codes on their products. The introductory multimedia presentation connects participants with a GS1 expert live via a telephone conference call, while following the presentation on the web page.

#### **8.3.2.7.4 Knowledge Series 101**

Members as well as non members can get a deeper understanding on some of the GS1 standards supporting electronic messaging, radio-frequency identification (RFID) and other technologies.

#### **8.3.2.7.5 Sessions at the GS1's Supply Chain Knowledge Centre**

Nothing can quite compare to the impact of a day spent at GS1 Australia's Supply Chain Knowledge Centre, which delivers a number of supply chain learning programs specifically developed for small, medium and large enterprises. The Supply Chain Knowledge Centre takes participants on an educational journey through the supply chain and is relevant to every sector of the economy. It demonstrates, in a clear and easily understandable manner, how sound supply chain management techniques can benefit your business and provide the foundation for current and future eCommerce strategies. The Supply Chain Knowledge Centre is a very effective way to introduce staff to the



fundamentals of supply chain management - from raw material, through manufacture, shipping and on to Point-of-Sale.

